



Better FTTx,
Better Life.

FCST022109-17 Ports

Pre-connected Fiber Access Terminal



Product Overview

FCST022109-17 Ports Pre-connected Fiber Access Terminal as the most advanced FTTX network distribution node equipment, provide quick and reliable connection, good protection and management for the FTTX network.

Product Advantages

- Protection level up to IP68.
- Onsite plug and play, rapid deployment.
- The interior is equipped with 1*16 PLC splitter.
- FAT does not need to be opened for site construction.
- Fully pre-connected design increases FAT installation efficiency by 80%+.

Product Specifications

Construction	Description
Max. Capacity	16 Cores
Material	PP&PC+ABS
Inlets/Outlets	1/16
Installation	Pole mounting, Aerial mounted, Wall-mounting
Protection Level	IP68
Splitter Type	1x16 PLC Splitter
Length	199mm 7.835in
Width	193mm 7.598in
Height	107mm 4.213in
Weight	900 g
Storage Temperature	-40° C ~ +65 ° C

Product Size

Unit:mm

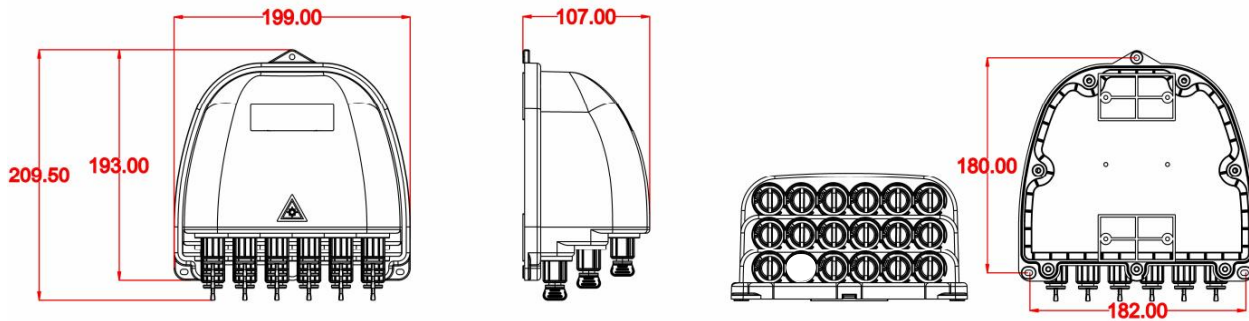

Ordering Information

FCST022109 -17Ports

Material Type	
1	PP
2	PC+ABS

Installation Accessories Type	
1	Wall mounted installation
2	Pole-mounted installation
3	Aerial mounted installation

Adapter Type	
1	Pre-connected Adapter - SC (XL)
2	HUAWEI mini SC Type
3	Corning Optitap Type
...	Customizable

Product Installation



Wall-mounted Installation

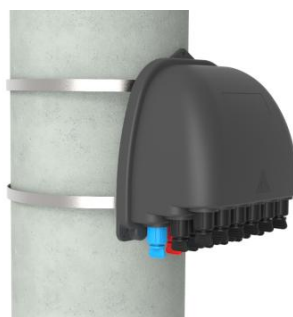

Pole-mounted Installation



Aerial-mounted Installation

Pre-connectorized Cables Option



Option 1--Pre-connectorized Cables 5mm

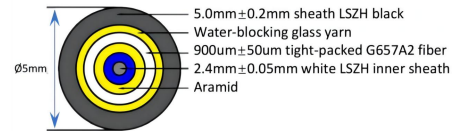

Option 2--Pre-Connectorized Fiber Drop Cable(2.0*5.0mm)

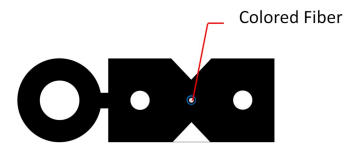

Packing Information



Construction	Description
Outside Dimension (L*W*H) mm	220*210*120
Weight/PC (kgs)	1
Carton Size (L*W*H) mm	460*440*635
Qty/CTN (pcs)	20
Weight/CTN (kgs)	20.1